

FIGURE 1. SEQUENTIAL POSITION CONTROL

INTRODUCTION

Power Op Amps are ideally suited for position control because their response time is fast compared to any mechanical drive train. The optoelectronic technique of position control can move to and maintain fixed index points on linear or rotary motion components while adding no linkages or independently moving parts. The resulting system features high reliability, accuracy and repeatability. If the integration of photodiode currents is required, select a power amplifier with an FET input to maintain very low bias current levels such that the integrating capacitor voltage will remain constant during periods when both photodiodes are not illuminated. Further selection criteria should be based on motor ratings and/or available power.

SEQUENTIAL POSITION CONTROL

In the circuit shown in Figure 1, the PA07 integrates the differential output of the pair of photodiodes and drives the motor in the proper direction until the photodiode currents are equal. This differential configuration negates the well known temperature and time instabilities of optoelectronic devices. To move between index points, a fixed input current is momentarily switched to the amplifier input causing the amplifier to drive the motor in the desired direction. The charge on C_F will maintain motor drive as the input current is switched off prior to reaching the index point. As the first photodiode is illuminated, its output reinforces the current direction of motion. As the second photodiode is illuminated, its current will reverse the motor drive, causing the system to lock to the index point.

As motor response and system inertia vary widely, C_F and R_F must be selected for the individual application to provide proper damping. C_F must be small enough to allow drive reversal before the index point passes the second photodiode or the system will continue on to the next index. Very small values of C_F can cause severe overshoot or oscillation leading to motor burnout and/or drive train failure. R_{F1} and R_{F2} are required to stabilize the control loop at the unity gain point and to minimize overshoot. R_L and C_L form a lead network which may be included to improve response time by enabling the amplifier to modify the motor drive based on a change of the sensor output. In this manner, a braking force can be applied to the motor prior to reaching the index point. The motor shown in Figure 1, having EMF of 14V, will apply a 46V stress across the conducting output transistor when reversed. With a duration longer than 5ms, the steady state secondary breakdown line of the SOA for the PA07 curves requires the current limits to be set to 1A. See PA07 data sheet.

SINGLE POINT POSITION CONTROL

A variation of the above technique shown in Figure 2 can be used to return a wheel to a single index point after rotating in either direction. The low inertia, fast response system will take the shorter route to the index point when switched from run to stop. The PA12A was selected for this application because it provides high power while keeping bias current levels low with respect to the photodiode currents. To improve response time, the lead network compensates for motor response lagging behind any change in drive voltage. A run control current of

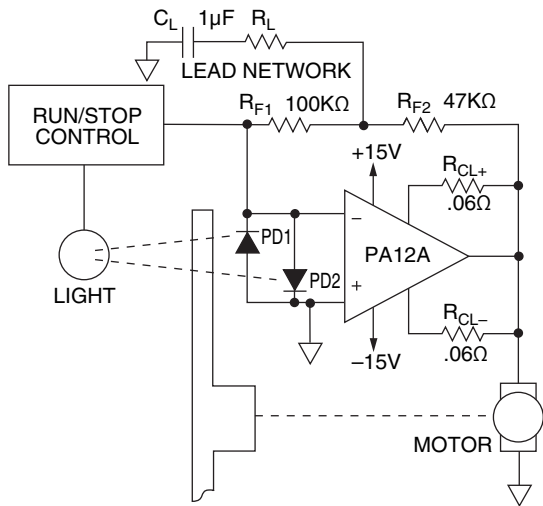

FIGURE 2. SINGLE POINT POSITION CONTROL
 sufficient amplitude to override the photodiode currents is fed to the amplifier inverting input. Removal of this current restores control to the photosensors.

POSITION CONTROL MASK

Figure 3 shows details of the wheel preparation and sensor placements at the stop index. Arrows indicate direction of rotation when the corresponding photodiode has the higher output. While it is theoretically possible to achieve a stable position on the opposite side of the wheel, system noise or a slight movement will imbalance the equal photodiode currents and the higher current sensor will receive even more light. This causes the wheel to seek the desired index point. Masking of the wheel at an angle to the radial softens the control function and prevents overshoot.

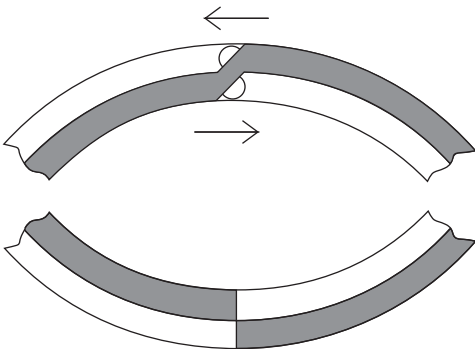

FIGURE 3. SINGLE INDEX POINT DISK

SPOT SIZE

Optimum relationship of beam size to active areas of the photodetectors is shown in Figure 4. A centered beam should illuminate half the photosensitive area of each diode. Too large

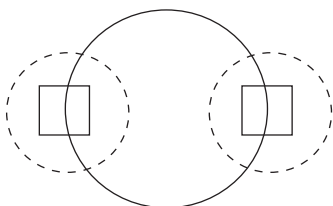

FIGURE 4. BEAM-SENSOR ALIGNMENT

a beam will produce no change of sensor output for a range of positions, while a smaller beam will produce a nonlinear transfer function near the center line between the photosensitive areas. This makes selection of C_F to dampen the circuit difficult and requires a higher intensity light source.

DIGITAL INTERFACING

For systems with digital control, Figure 5 illustrates a method not requiring generation of bipolar control signals thus saving the cost of digital to analog conversion. When logic lines are low, the signal diodes will not conduct. This condition leaves control to the photodiodes. A high level on line 2 will cause current to flow to the summing junction and the amplifier will swing negative. A high level on line 1 will raise the summing junction voltage above ground, and the amplifier will swing positive. Select a resistance value such that a high logic level will provide at least twice the maximum current from each photodiode to insure control override regardless of photodiode signals.

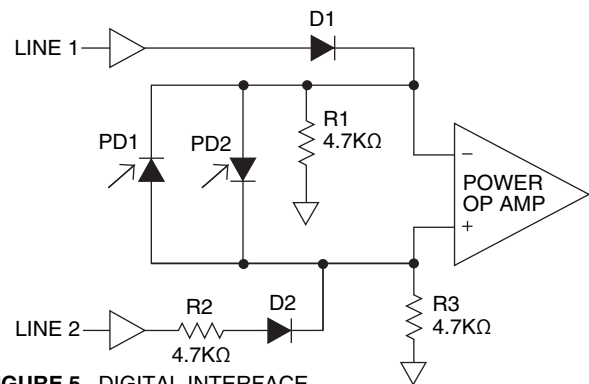

FIGURE 5. DIGITAL INTERFACE

DUAL SENSORS

For applications requiring high precision, the use of a dual element position sensing PD1 (Figure 5) will allow smaller beam size, tighter beam control and provide better thermal equilibrium. The specified resolution of the detector recommended for this application is better than .0127mm (.0005 inch). The detector is a three terminal device requiring a current inverter as shown in Figure 6 to achieve the differential configuration. Two equal resistors, R1 and R2, should be scaled to the maximum photodiode current and swing capability of the signal amplifier.

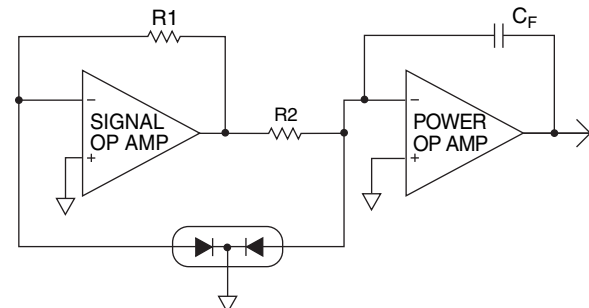

FIGURE 6. CURRENT INVERSION